

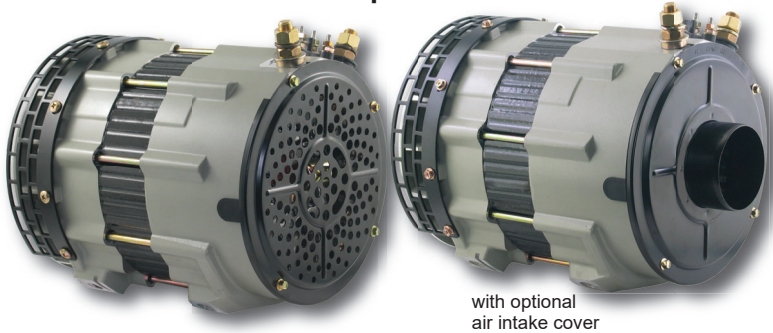

HD BRUSHLESS

1300-40231
24 Volts 400 Amps



with optional
air intake cover

Designed to be used with:

SERIES 300

MASTERVOLT
Alpha Pro III Voltage Regulator*



*Sold separately

MASTERVOLT

PRODUCT SPECIFICATIONS

Part number	1300-40231
System Voltage	24V
Rated Output	400A
Output @ 2000 rpm	260A
Ground	Isolated
Mounting	Cradle
Rotation	Bidirectional
Temperature limits:	Low - 40°C / -40°F
	High 93°C / 200°F
	High 110°C / 230°F (with fresh air intake hose)
Speed limits:	7000 RPM continuous
	8000 RPM intermittent
Coating	Corrosion-Resistant E-Coated
Weight	77 Lbs / 35 Kg.
Regulator	Alpha Pro III (Remote) <i>Please contact your dealer</i>



with optional
air precleaner

RECOMMENDED FOR:

- Coach & Transit Busses
- Marine
- Mining
- Construction
- Industrial

NOTE:

This DelStar 1300-40231 alternator, meets the marine requirements for Ignition Protection on gas or diesel engines of ISO 8846, USCG, stated in Title 33 CFR 183.410, SAE J1171 and International CE Standards.

ACCESSORIES:

- Air Intake Cover # 46400-212
- Air Precleaner # 4800-2101

ALTERNATORS

SERIES 300

OUTLINE

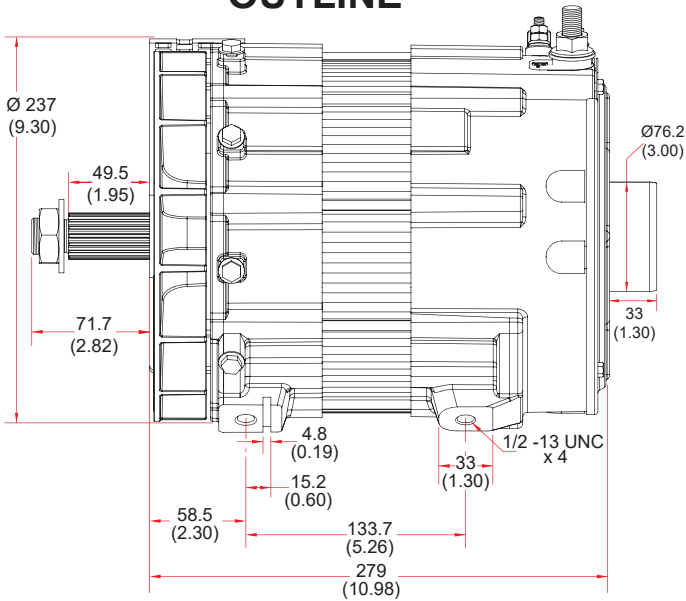

Dimensions are listed in mm over (in)

PERFORMANCE CURVES

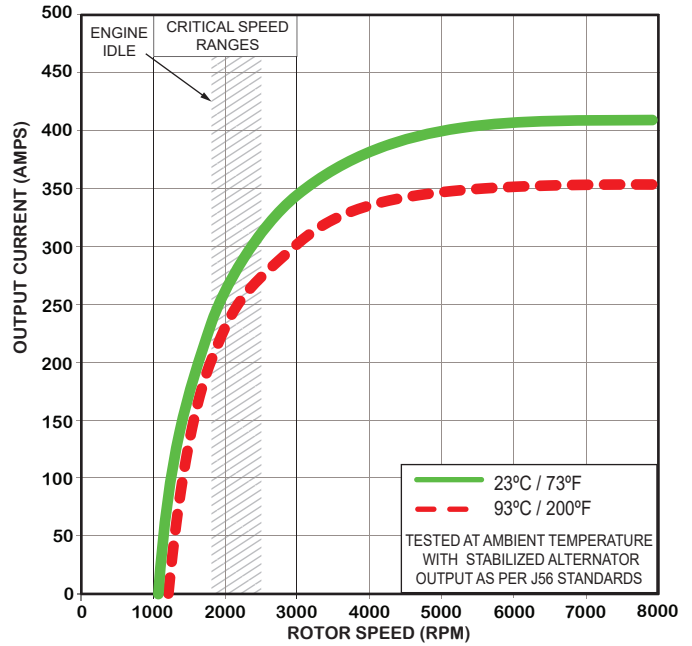

1300-40231
24 Volts, 400 Amps

CONNECTIONS

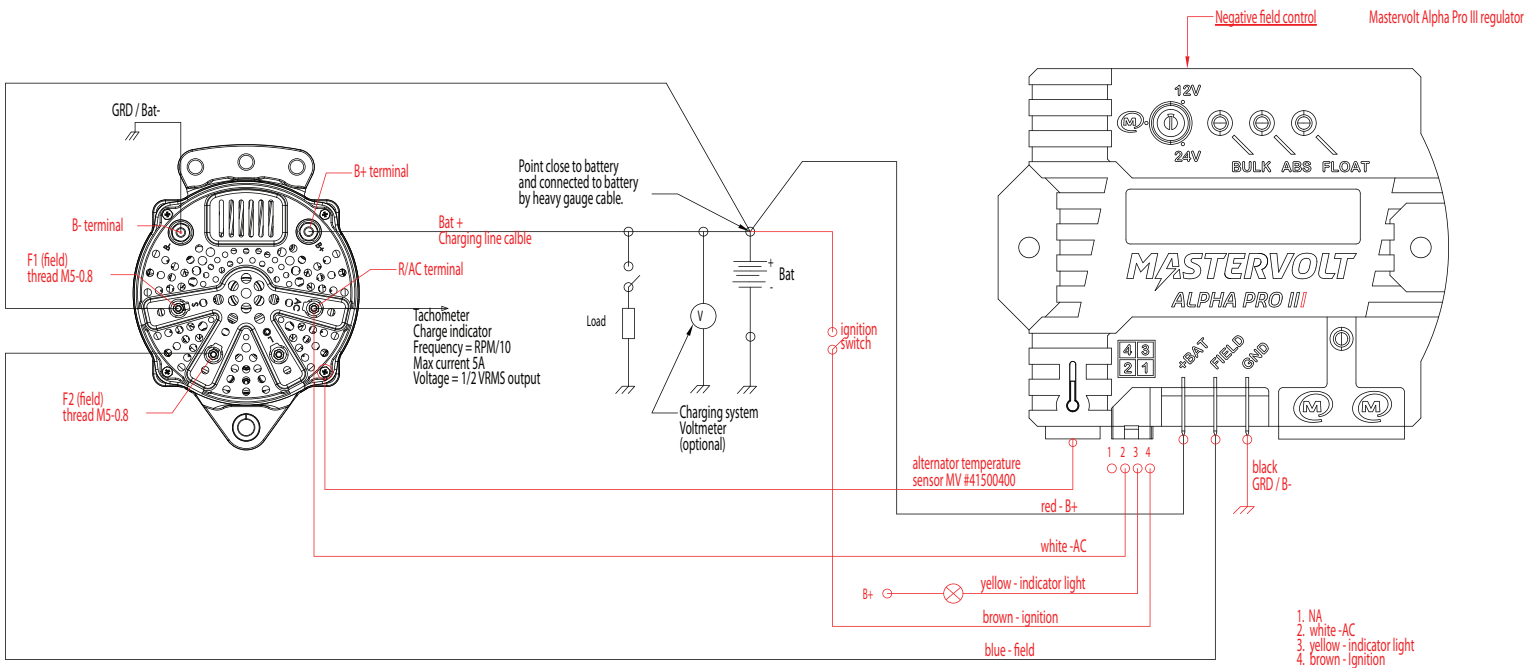

CANADA & EXPORT SALES

Dixie Electric
517 Basaltic Road
Concord, ON
Canada L4K 4W8
Tel: 905-879-0533 | 800-461-5799
Fax: 905-879-0532
E-Mail: sales@dixie-electric.com
www.dixie-electric.com



U.S.A. SALES

Dixie Electric Inc.
5600 Pioneer Creek Drive, Suite D
Maple Plain, MN 55359
U.S.A.
Tel: 763-475-6629 | 800-478-0608
Fax: 763-475-6635 | 800-392-8719
E-Mail: mn.sales@dixie-electric.com
www.dixie-electric.us