

100-30201
28 Volts 330 Amps



With Air Precleaner (as supplied)

PRODUCT SPECIFICATIONS

Part number	100-30201
System Voltage	24V
Rated Output	330A
Output @ 2000 rpm	225A
Ground	Negative
Mounting	Cradle
Rotation	Bidirectional
Temperature limits:	
Low	- 40°C / -40°F
High	93°C / 200°F (with air precleaner)
High	110°C / 230°F (with fresh air intake hose)
Speed limits:	
	7000 RPM continuous
	8000 RPM intermittent
Coating	Corrosion-Resistant E-Coated
Weight	77 Lbs / 35 Kg.
Regulator	Remote
Relay/AC	M5 terminal

ACCESSORIES:

Remote Voltage Regulator	# 3500-50251
Air Precleaner	# 4800-2101
Oil Line Cap Kit	# 4900-5000
(oil cooled to air cooled conversion)	

RECOMMENDED FOR:

- Transit Bus
- Motor Coach
- Marine
- Mining
- Industrial

NOTE:

This DelStar 100-30201 alternator, meets the marine requirements for Ignition Protection on gas or diesel engines of ISO 8846, USCG, stated in Title 33 CFR 183.410, SAE J1171 and International CE Standards.

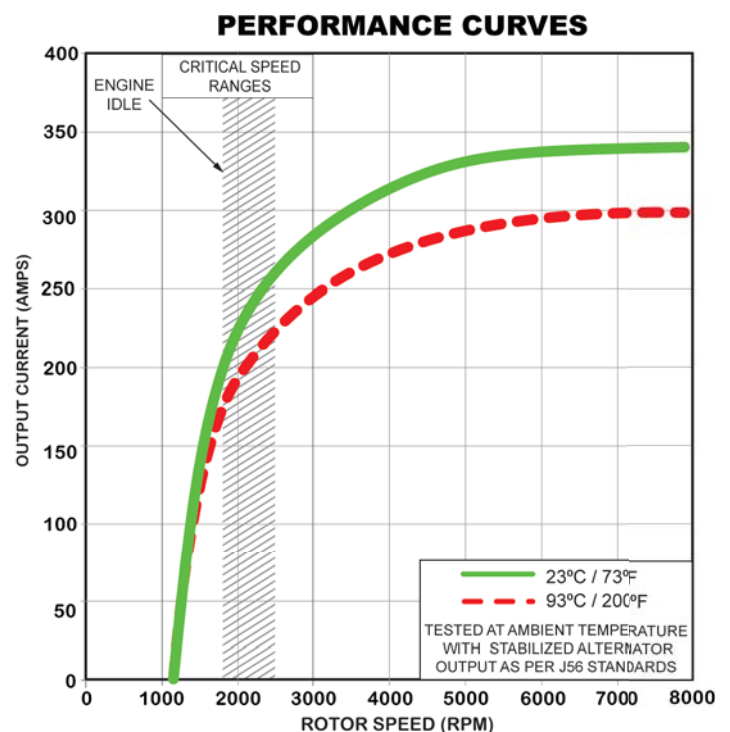

OUTLINE

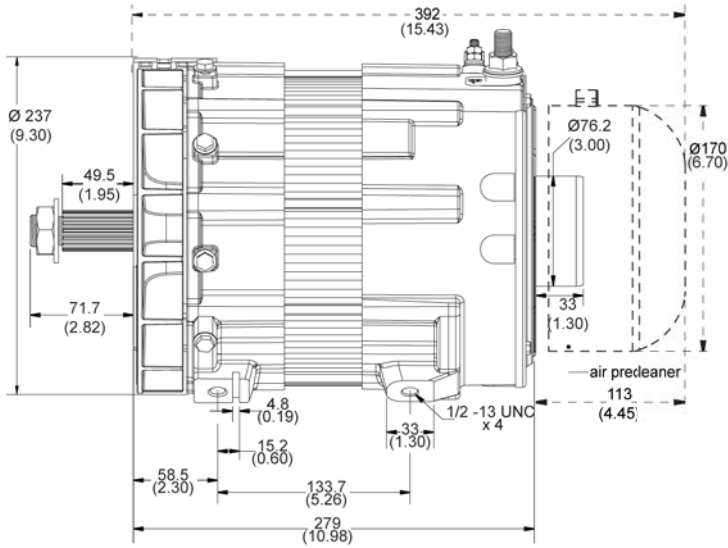

CONNECTIONS

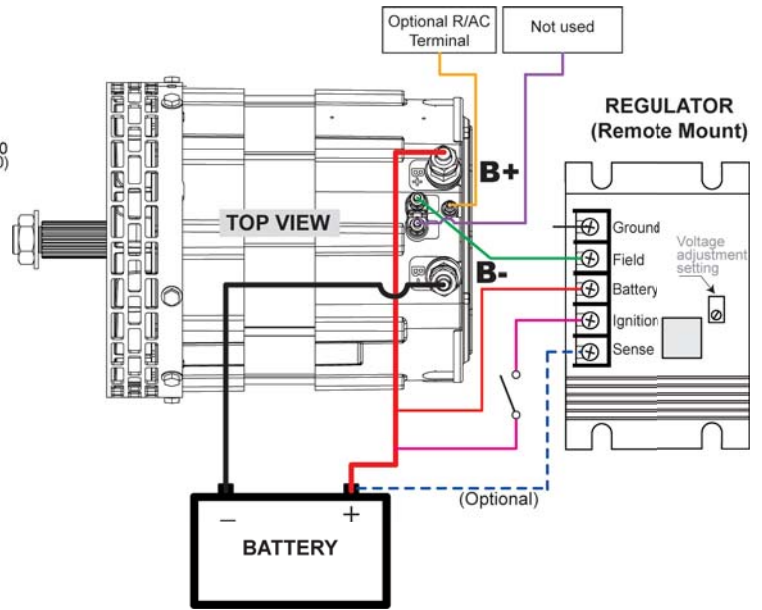

100-30201

28 Volts 330 Amps

ELECTRICAL SCHEMATIC

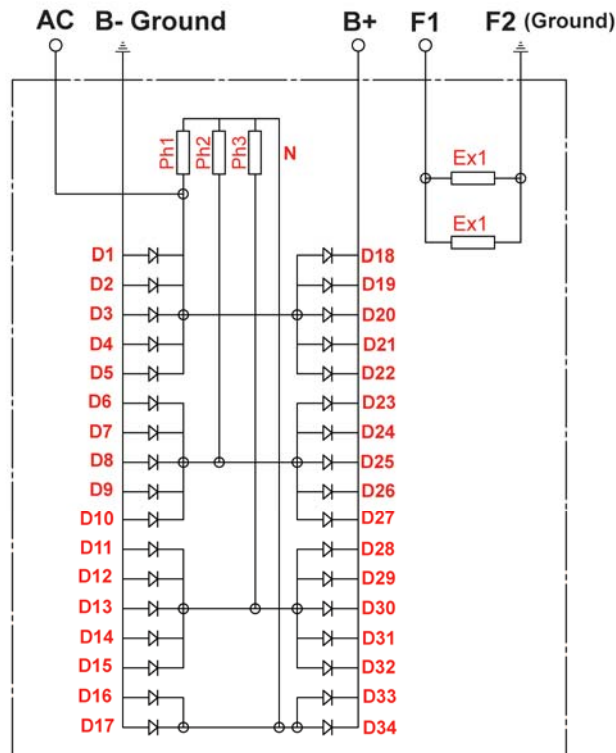

D100-30201 - 160226

CANADA

Dixie Electric Ltd.
517 Basaltic Road
Concord, ON.
Canada L4K 4W8

Tel.: 905-879-0533 800-461-5799
Fax: 905-879-0532
E-Mail: sales@dixie-electric.com
Web Site: www.dixie-electric.com



U.S.A.

Dixie Electric Inc.
17100 Medina Rd, Suite 100
Minneapolis, MN.
U.S.A. 55447-1249

Tel.: 763-475-6629 800-478-0608
Fax: 763-475-6635 800-392-8719
E-Mail: mn.sales@dixie-electric.com
Web Site: www.dixie-electric.com