



HD BRUSHLESS

SERIES 170

1170-10201,-D
24 Volts 200 Amps

Designed to be used with:

MASTERVOLT
Alpha Pro III Voltage Regulator*



Please contact your **MASTERVOLT** dealer



1170-10201-D
with air intake cover

PRODUCT SPECIFICATIONS

Part number	1170-10201
System Voltage	24V
Rated Output	200A
Outout @ 2000 rpm	114A
Ground	Insulated
Mounting	J-180 4" Hinge
Rotation	Bidirectional
Temperature limits:	Low - 40°C / -40°F
	High 110°C / 230°F
	High 125°C / 257°F (with fresh air intake)
Speed limits:	7000 RPM continuous
	8000 RPM intermittent
Coating	Corrosion-Resistant E-Coated
Weight	38 Lbs / 17.4 Kg.
Regulator	Alpha Pro III (Remote)

RECOMMENDED FOR:

- Marine
- Mining
- Construction
- Industrial
- Utility Vehicles

ACCESSORIES:

- Air Intake Cover # 46400-171

NOTE:

This DelStar 1170-10201 alternator, meets the marine requirements for Ignition Protection on gas or diesel engines of ISO 8846, USCG, stated in Title 33 CFR 183.410, SAE J1171 and International CE Standards.

ALTERNATORS

SERIES 170

OUTLINE

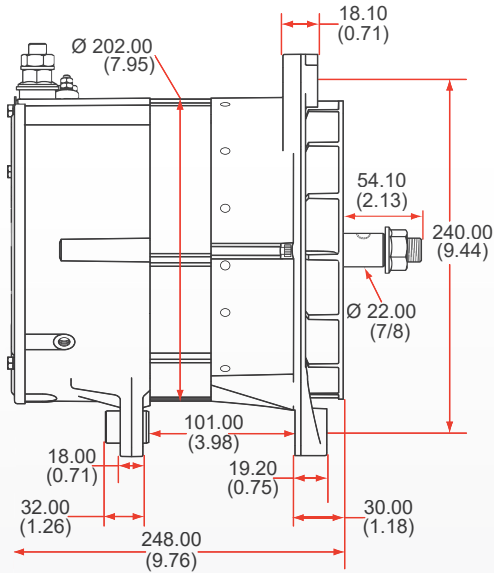

Dimensions are listed in mm over (in)

PERFORMANCE CURVES

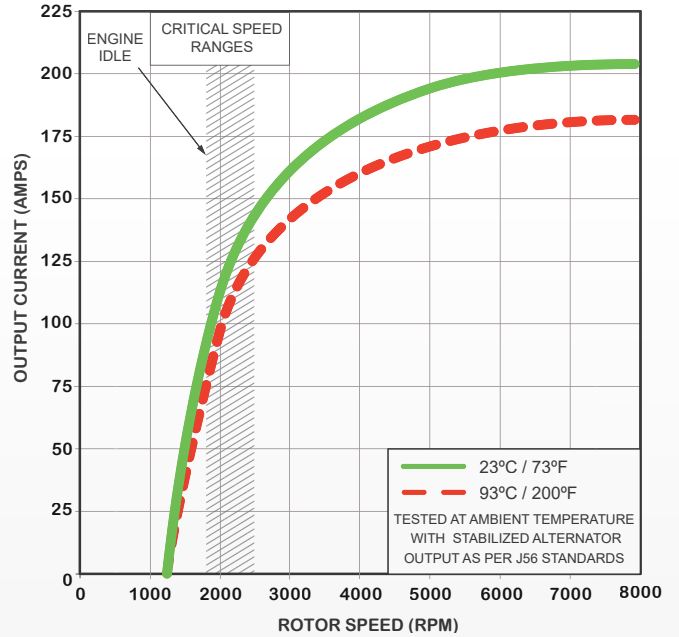

1170-10201
24 Volts, 200 Amps

CONNECTIONS

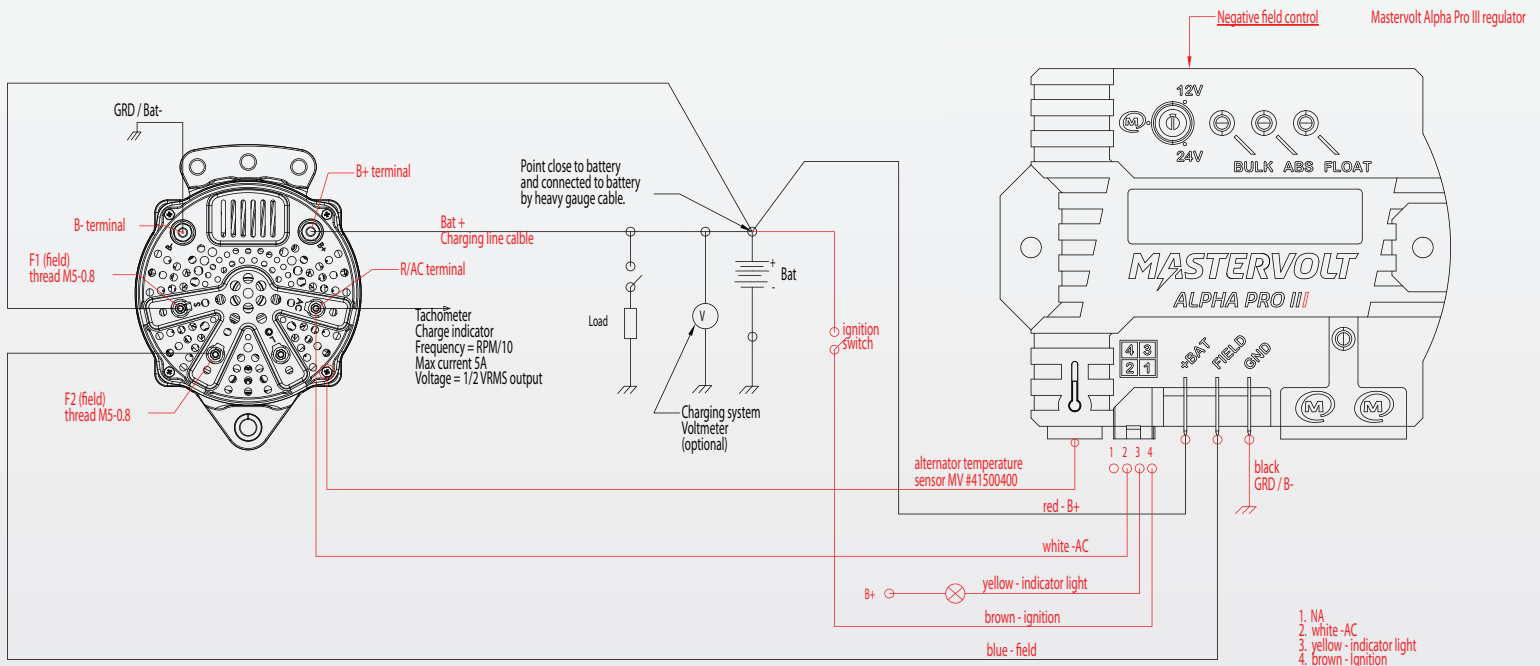

CANADA & EXPORT SALES

Dixie Electric
517 Basaltic Road
Concord, ON
Canada L4K 4W8
Tel: 905-879-0533 | 800-461-5799
Fax: 905-879-0532
E-Mail: sales@dixie-electric.com
www.dixie-electric.com



U.S.A. SALES

Dixie Electric Inc.
5600 Pioneer Creek Drive, Suite D
Maple Plain, MN 55359
U.S.A.
Tel: 763-475-6629 | 800-478-0608
Fax: 763-475-6635 | 800-392-8719
E-Mail: mn.sales@dixie-electric.com
www.dixie-electric.us