

### 100-17219,-D 24 Volts 175 Amps

#### PRODUCT SPECIFICATIONS

<b>Part number</b>	100-17219
<b>System Voltage</b>	24V
<b>Rated Output</b>	175A
<b>Output @ 2000 rpm</b>	70A
<b>Ground</b>	Isolated
<b>Mounting</b>	Pad
<b>Rotation</b>	Bidirectional
<b>Temperature limits:</b>	
Low	-40°C / -40°F
High	125°C / 257°F
<b>Speed limits:</b>	8000 RPM continuous 9000 RPM intermittent
<b>Coating</b>	Corrosion-Resistant E-Coated
<b>Weight</b>	38 Lbs / 17.4 Kg.
<b>Regulator</b>	Integral
<b>Excitation</b>	Self-excited
<b>Indicator Light</b>	Yes
<b>Remote Sense</b>	Yes
<b>Soft Start Delay (SSD)</b>	Yes
<b>Load Response Control (LRC)</b>	Yes
<b>Field Short Circuit Protection</b>	Yes
<b>Load Dump Protection</b>	Yes
<b>Overvoltage Shut-Down (OSD)</b>	Yes

#### RECOMMENDED FOR:

- Utility Vehicles
- Marine, Mining
- Industrial
- Construction



**100-17219**



**100-17219-D**  
with air intake cover

#### NOTE:

*This DelStar 100-17219 alternator, meets the marine requirements for Ignition Protection on gas or diesel engines of ISO 8846, USCG, stated in Title 33 CFR 183.410, SAE J1171 and International CE Standards.*

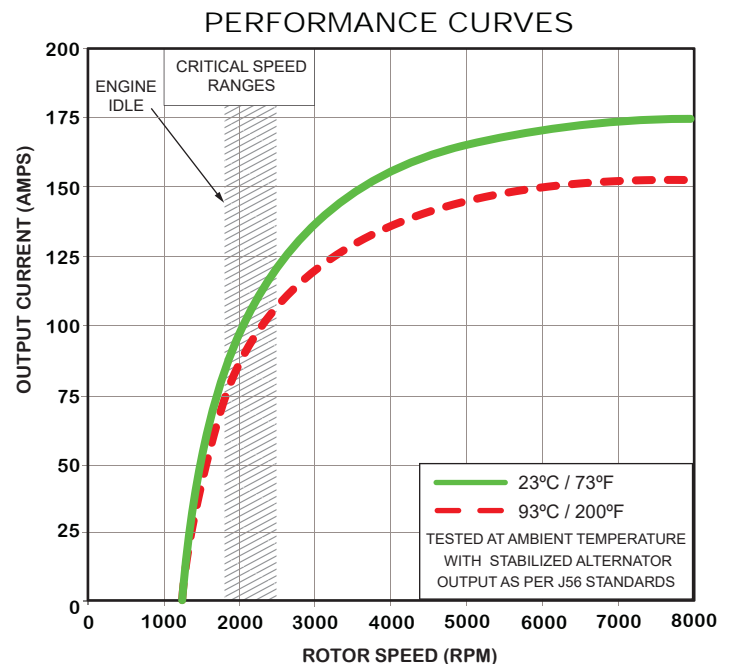

### OUTLINE

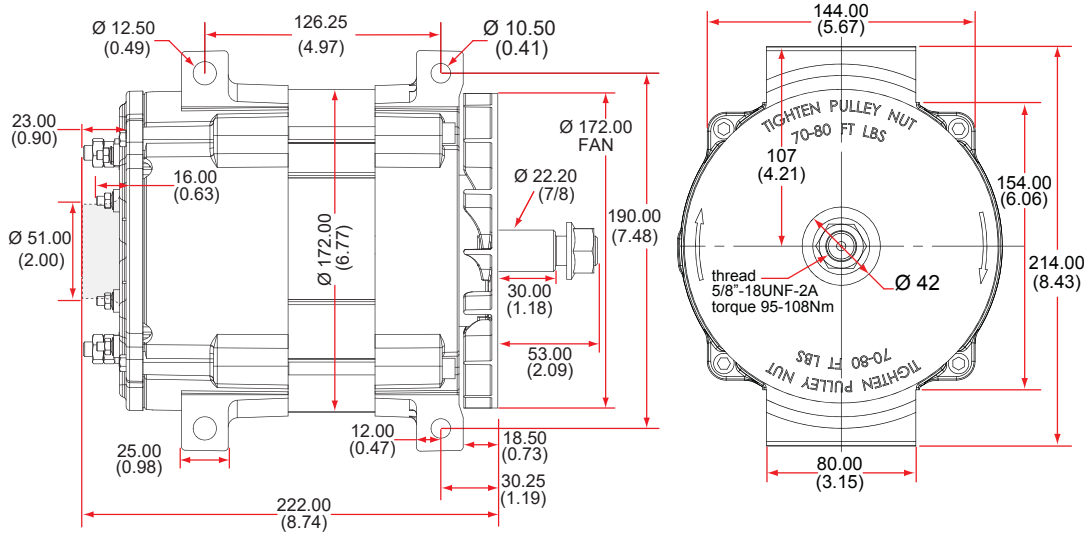

### CONNECTIONS

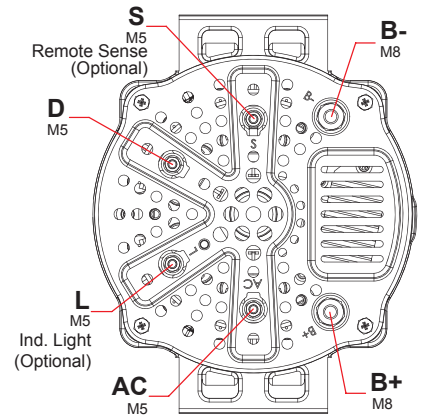

100-17219

24 Volts 175 Amps

### ELECTRICAL SCHEMATIC

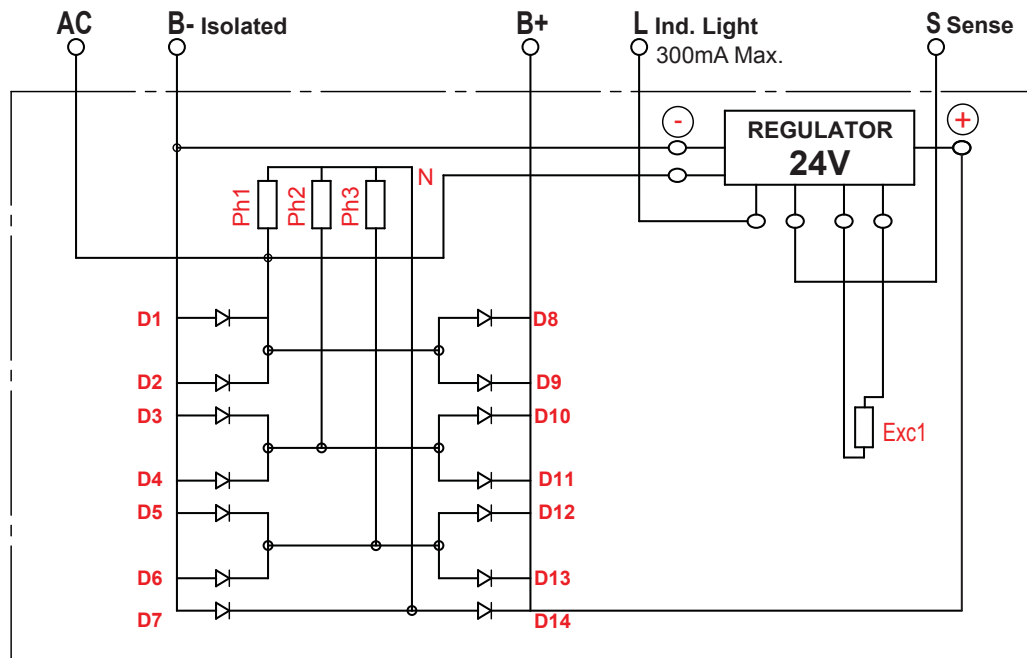

D100-17219 - 150616 - Rev. 170405 - Rev. 180226

#### CANADA

Dixie Electric Ltd.  
517 Basaltic Road  
Concord, ON.  
Canada L4K 4W8

Tel.: 905-879-0533 800-461-5799  
Fax: 905-879-0532  
E-Mail: sales@dixie-electric.com  
Web Site: www.dixie-electric.com



#### U.S.A.

Dixie Electric Inc.  
17100 Medina Rd, Suite 100  
Minneapolis, MN.  
U.S.A. 55447-1249

Tel.: 763-475-6629 800-478-0608  
Fax: 763-475-6635 800-392-8719  
E-Mail: mn.sales@dixie-electric.com  
Web Site: www.dixie-electric.us