

100-17218,-D 28 Volts 240 Amps

PRODUCT SPECIFICATIONS

Part number	100-17218
System Voltage	24V
Rated Output	240A
Output @ 2000 rpm	90A
Ground	Isolated
Mounting	Pad
Rotation	Bidirectional
Temperature limits:	
Low	-40°C / -40°F
High	110°C / 230°F
High	125°C / 257°F (with fresh air intake)
Speed limits:	
	8000 RPM continuous
	9000 RPM intermittent
Coating	Corrosion-Resistant E-Coated
Weight	38 Lbs / 17.4 Kg.
Regulator	Remote



100-17218



100-17218-D

with air intake cover

NOTE:

This DelStar 100-17218,-D alternator, meets the marine requirements for Ignition Protection on gas or diesel engines of ISO 8846, USCG, stated in Title 33 CFR 183.410, SAE J1171 and International CE Standards.

RECOMMENDED FOR:

- Utility Vehicles
- Marine, Mining
- Industrial
- Construction

PERFORMANCE CURVES

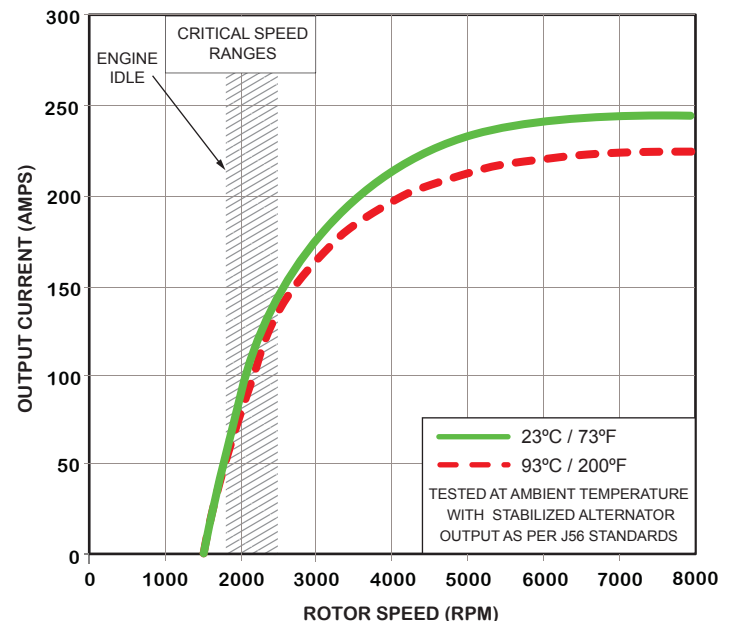

OUTLINE

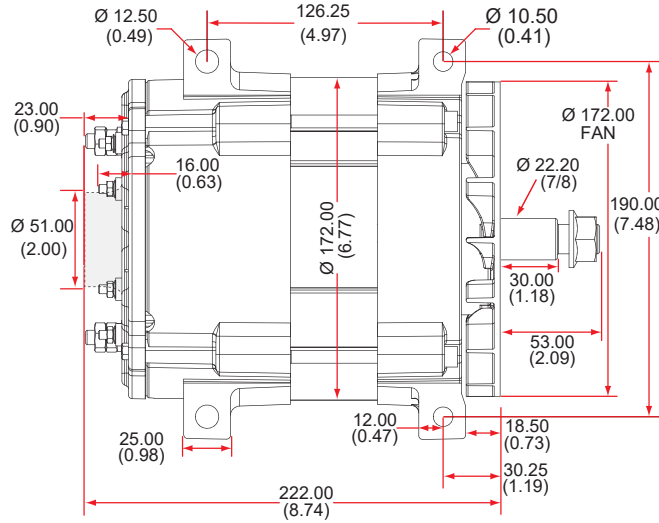

CONNECTIONS

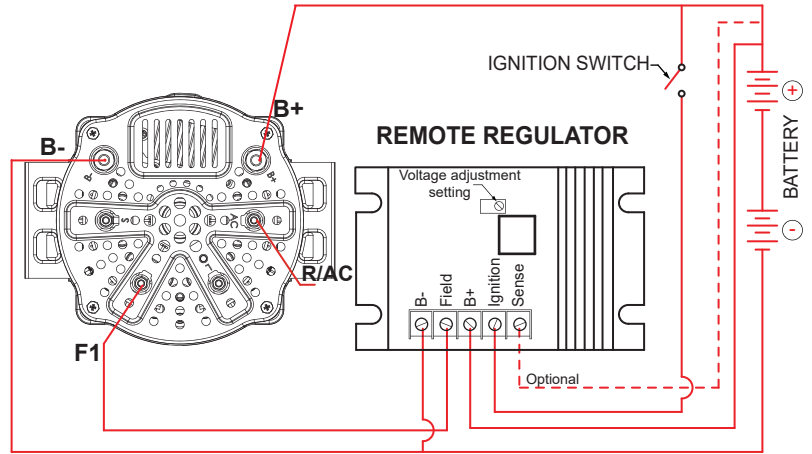

Dimensions are listed in mm over (in)

100-17218

28 Volts 240 Amps

ELECTRICAL SCHEMATIC

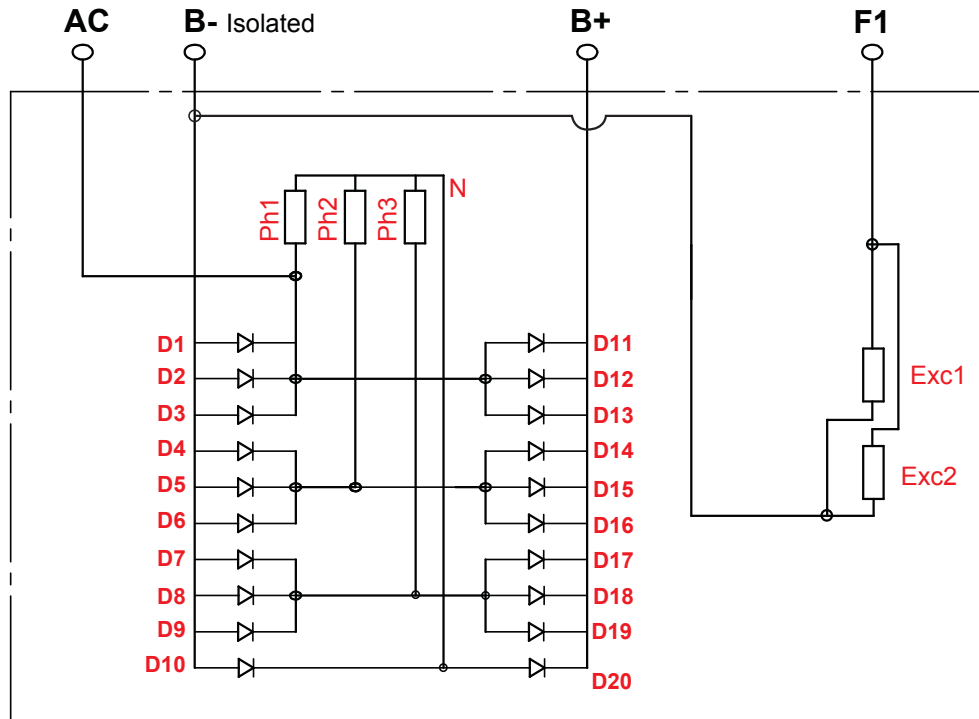

D100-17218 - 160324 - Rev. 180226

CANADA

Dixie Electric Ltd.
517 Basaltic Road
Concord, ON.
Canada L4K 4W8

Tel.: 905-879-0533 800-461-5799
Fax: 905-879-0532
E-Mail: sales@dixie-electric.com
Web Site: www.dixie-electric.com



U.S.A.

Dixie Electric Inc.
17100 Medina Rd, Suite 100
Minneapolis, MN.
U.S.A. 55447-1249

Tel.: 763-475-6629 800-478-0608
Fax: 763-475-6635 800-392-8719
E-Mail: mn.sales@dixie-electric.com
Web Site: www.dixie-electric.us