



HD BRUSHLESS

DelStar®

SERIES 170

100-17116,-D

12 Volts 350 Amps

Designed to be used with:

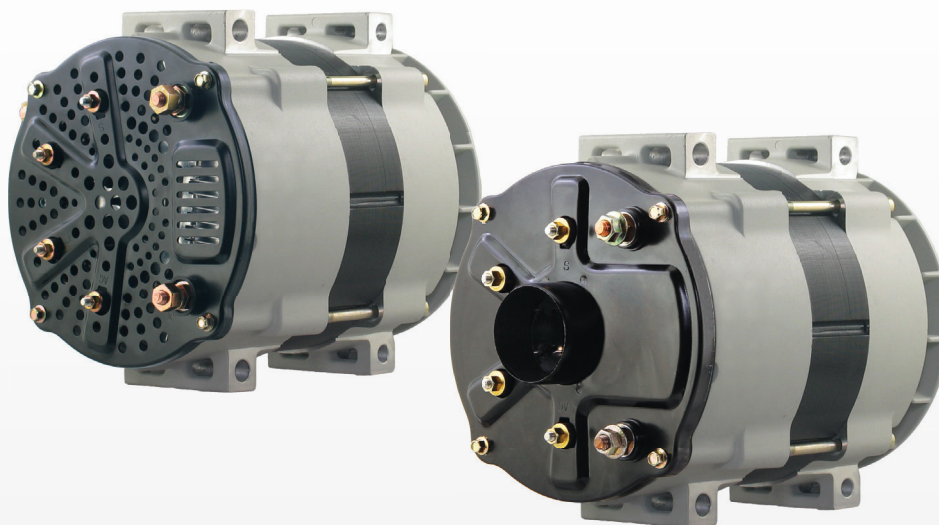

Please contact your **MASTERVOLT** dealer

100-17116-D
with air intake cover

PRODUCT SPECIFICATIONS

Part number	100-17116
System Voltage	12V
Rated Output	350A
Output @ 2000 rpm	210A
Ground	Isolated
Mounting	Pad
Rotation	Bidirectional
Temperature limits:	
Low	-40°C / -40°F
High	110°C / 230°F
High	125°C / 257°F (with fresh air intake)
Speed limits:	
	8000 RPM continuous
	9000 RPM intermittent
Coating	Corrosion-Resistant E-Coated
Weight	38 Lbs / 17.4 Kg.
Regulator	Remote

RECOMMENDED FOR:

- School & Shuttle Buses
- Utility Vehicles
- Marine & Mining
- Agricultural
- Construction & Industrial

NOTE:

This DelStar 100-17116 alternator, meets the marine requirements for Ignition Protection on gas or diesel engines of ISO 8846, USCG, stated in Title 33 CFR 183.410, SAE J1171 and International CE Standards.

ALTERNATORS

DelStar[®] | SERIES 170

OUTLINE

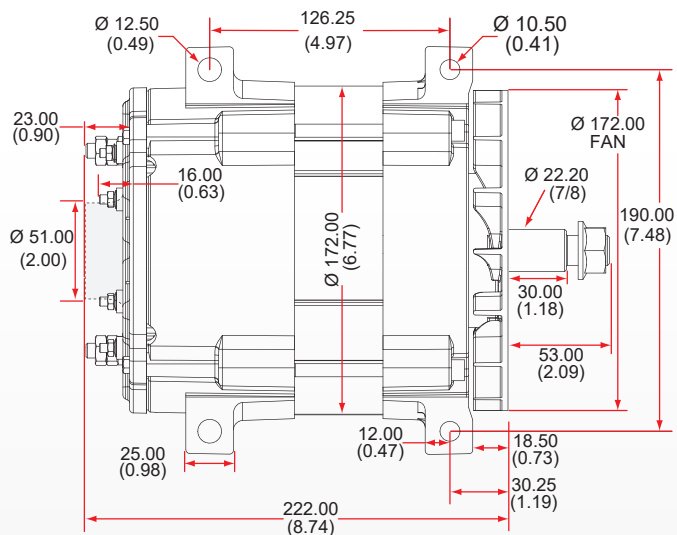

PERFORMANCE CURVES

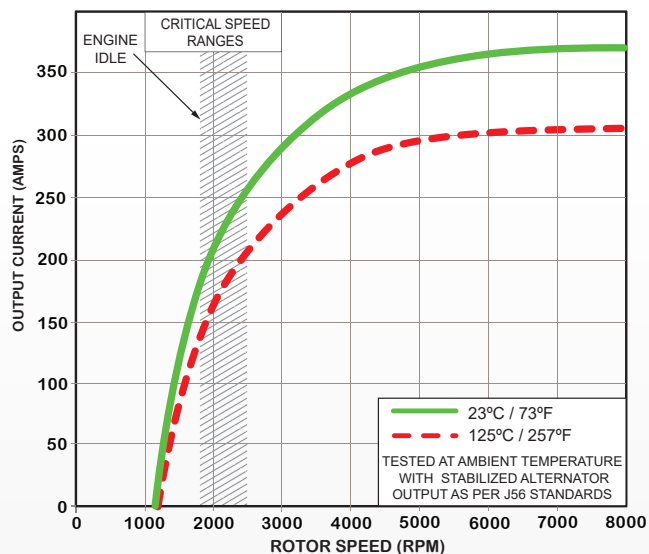

Dimensions are listed in mm over (in)

100-17116

12 Volts, 350 Amps

CONNECTIONS

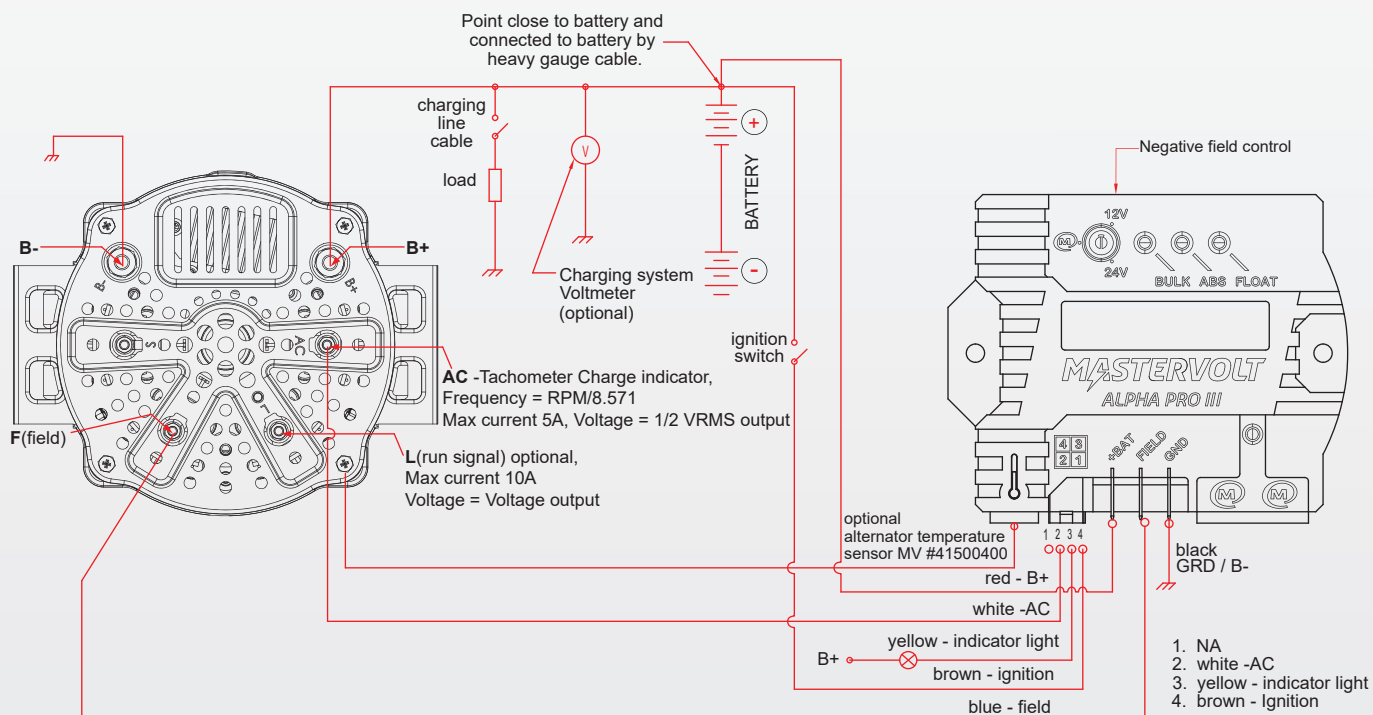

CANADA & EXPORT SALES

Dixie Electric
517 Basaltic Road
Concord, ON
Canada L4K 4W8

Tel: 905-879-0533 | 800-461-5799
Fax: 905-879-0532
E-Mail: sales@dixie-electric.com
www.dixie-electric.com



U.S.A. SALES

Dixie Electric Inc.
5600 Pioneer Creek Drive, Suite D
Maple Plain, MN 55359
U.S.A.

Tel: 763-475-6629 | 800-478-0608
Fax: 763-475-6635 | 800-392-8719
E-Mail: mn.sales@dixie-electric.com
www.dixie-electric.us