

100-16202,-D 28 Volts 150 Amps

PRODUCT SPECIFICATIONS

Part number	100-16202
System Voltage	24V
Rated Output	150A
Output @ 2000 rpm	55A
Ground	Isolated
Mounting	J180 4" Hinge
Rotation	CW
Temperature limits:	
Low	-40°C / -40°F
High	110°C / 230°F
High	125°C / 257°F (with fresh air intake)
Speed limits:	
	8000 RPM continuous
	9000 RPM intermittent
Coating	Corrosion-Resistant E-Coated
Weight	28 Lbs / 12.7 Kg.
Regulator	Remote

100-16202



100-16202-D

with air intake cover



NOTE:

This DelStar 100-16202 alternator, meets the marine requirements for Ignition Protection on gas or diesel engines of ISO 8846, USCG, stated in Title 33 CFR 183.410, SAE J1171 and International CE Standards.

PERFORMANCE CURVES

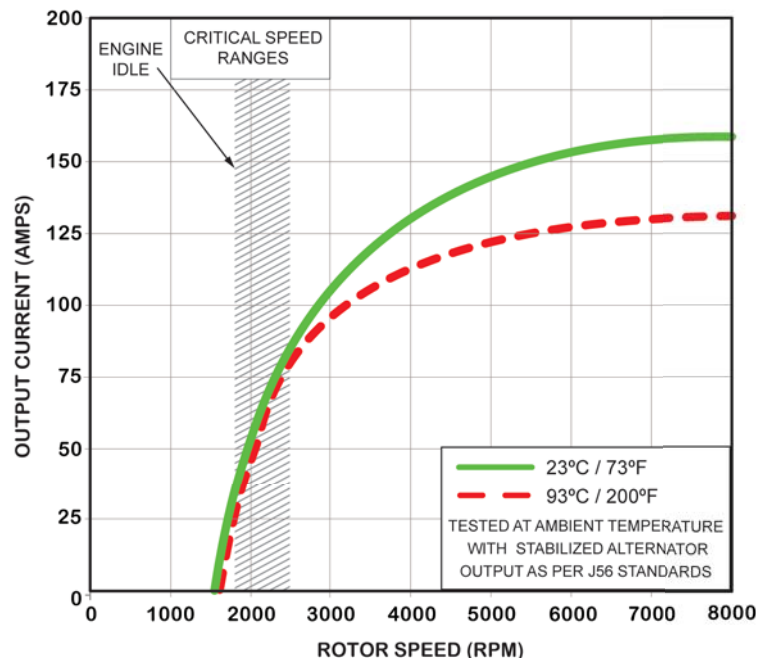

RECOMMENDED FOR:

- School & Shuttle Buses
- Utility Vehicles
- Marine & Mining
- Agricultural
- Construction & Industrial

OUTLINE

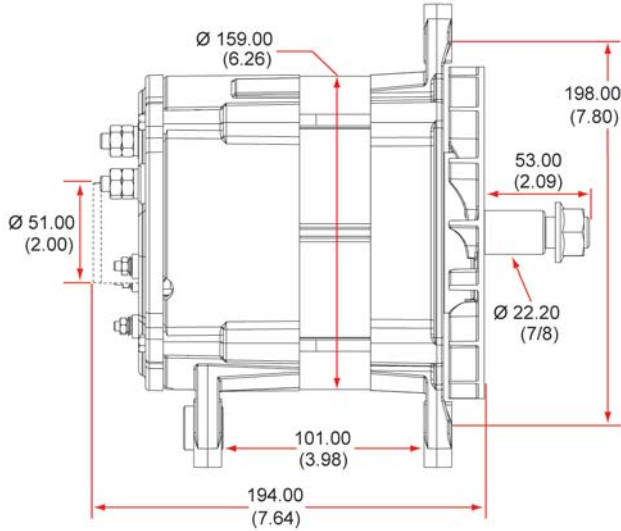

Dimensions are listed in mm over (in)

CONNECTIONS

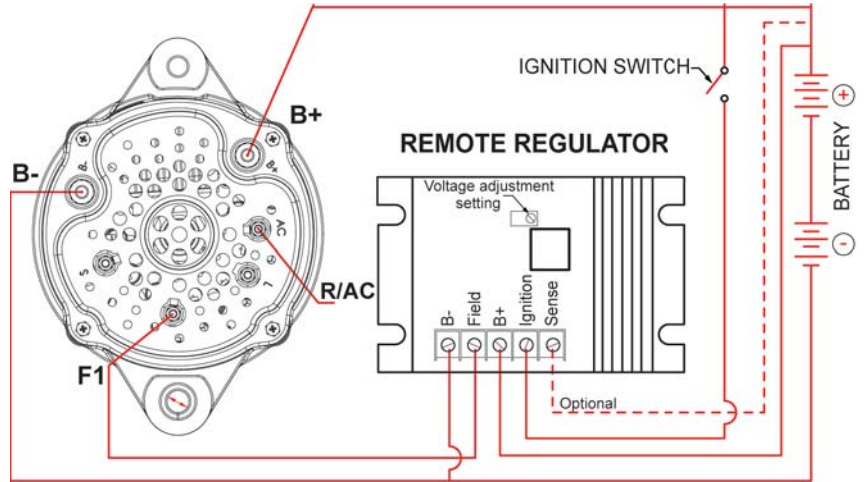

If the vehicle has an ignition (excite) circuit, connect wire to "D" (dummy) terminal.

100-16202

28 Volts 150 Amps

ELECTRICAL SCHEMATIC

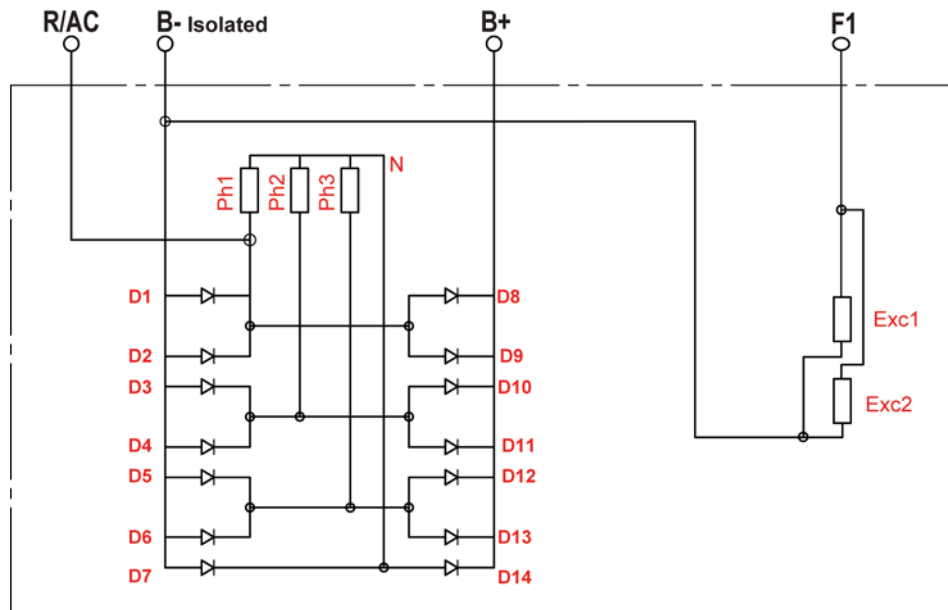

D100-16202 - 151110

CANADA & EXPORT SALES

Dixie Electric Ltd. Tel.: 905-879-0533 800-461-5799
 517 Basaltic Road Fax: 905-879-0532
 Concord, ON. E-Mail: sales@dixie-electric.com
 Canada L4K 4W8 Web Site: www.dixie-electric.com



U.S.A. SALES

Dixie Electric Inc. Tel.: 763-475-6629 800-478-0608
 17100 Medina Rd, Suite 100 Fax: 763-475-6635 800-392-8719
 Minneapolis, MN. E-Mail: mn.sales@dixie-electric.com
 U.S.A. 55447-1249 Web Site: www.dixie-electric.com